

**INFORMAL BID REQUEST  
FOR  
PLUMBING SERVICES  
SAN FRANCISCO UNIFIED SCHOOL DISTRICT  
PROP A 2003 BOND GREEN SCHOOLYARD PROGRAM**

---

**DATE/TIME FOR SUBMITTAL OF BID PROPOSAL:**                    **THURSDAY, DECEMBER 1, 2011, 2:00 PM** at  
135 Van Ness Avenue, Room 216, San Francisco, CA 94102

**BID DOCUMENTS AVAILABILITY:**    **ENCLOSED**

**NOTICE IS HEREBY GIVEN** that the above-named California School District, acting by and through its Board of Education, hereinafter "the District" will receive up to, but not later than the above-stated date and time, Bid Proposals for the Contract for the Work of the Project generally described as: **IRRIGATION PLUMBING REPAIR FOR VARIOUS SITES, PROJECT NUMBER 10786.**

**PROJECT SCOPE OF WORK.** The scope of work includes but is not limited to the replacement of the current backflow preventer with a Reduced Pressure (RP) backflow preventer at International Studies Academy (formerly Bryant ES), Leonard Flynn ES and West Portal ES. Please see scope of work description (Attachment A) for details.

**SUBMIT QUOTES.** Provide two copies of the response to the informal bid request. Provide complete name and contact information including email address so that notification of project clarifications and amendments can be issued. Bidders who fail to provide their name and contact information may be disqualified should their submittal fail to consider any clarifications or changes issued subsequent to the initial informal bid request.

Questions and requests for clarifications regarding this informal bid request should be submitted in writing. Direct your inquiries and submit your bids to the project manager below.

Lori Shelton, Project Manager  
Prop A Bond Green Schoolyard Program  
135 Van Ness Avenue, Room 216  
San Francisco, CA 94102  
W: 415.241.6152 ext. 1557  
F: 415.241.6148  
E: [SheltonL@sfusd.edu](mailto:SheltonL@sfusd.edu)

1. Proposed Fee and Basis of Charges: Submit an outline of the fee proposal to undertake the items described in the detailed scope of work. Submission should include separate line items for materials, labor, equipment and overhead & profit by school site. Hourly labor rates should be provided.
2. Administration Requirements: Successful bidders will be required to maintain in full force and effect, at their own expense, the following insurances with companies acceptable to the SFUSD:

- a) Worker's Compensation coverage limits should be \$1,000,000 (as required by the State of California and Employer's Liability Coverage)
- b) General Liability limits should be \$1,000,000 (Occurrence Form CG0001)
- c) Automobile Liability limits should be \$1,000,000 (ISO from CA 0001, Code 1)
- d) Professional Liability limits should be \$ 1,000,000
- e) Original wet signed Certificates of Insurance with Endorsements for General and Automobile Liabilities on CG 20 10 11 85 are required.
- f) San Francisco Unified School District, its Board, Officers and employees should be named as additional insured on General Liability and Automobile Liability by Endorsement, to be provided with Certificate, specifying the San Francisco Unified School District is noticed by the Company as an Additional Insured entitled to a 30-day written mailed notice.
- g) Proof of Current, Valid California Contractor's License (license number).

**STANDARD AGREEMENT:** The consultant's fee shall be set out in the SFUSD Construction Agreement Proposal. Compensation normally shall be on the basis of the approved schedule of services.

The unit hourly rates shall compensate for all costs associated with the item including but not limited to materials, equipment, travel, pager services, phone service calls, reproductions, mailing, readiness to serve and profit. Payment will be approved on a performance basis for a total figure not to exceed the budget set for the project. SFUSD WILL ONLY PAY FOR ACTUAL TIME ON THE JOB; NO TRAVEL TIME OR COST WILL BE PAID.

**DOCUMENTS ACCOMPANYING BID.** Each Bid shall be accompanied by the (a) completed and signed Construction Agreement Proposal form, pages 1 thru 7 and (b) completed and signed W-9 form. All information or responses of a Bidder in its Bid Proposal and other documents accompanying the Bid Proposal shall be complete, accurate and true; incomplete, inaccurate or untrue responses or information provided therein by a Bidder shall be grounds for the District to reject such Bidder's Bid Proposal for non-responsiveness.

**PREVAILING WAGE RATES.** Pursuant to California Labor Code § 1773, the Director of the Department of Industrial Relations of the State of California has determined the generally prevailing rates of wages in the locality in which the Work is to be performed. Copies of these determinations, entitled "A PREVAILING WAGE SCALE" is maintained at the District's Contract Office, and is available to any interested party upon request. The Contractor awarded the Contract for the Work shall post a copy of all applicable prevailing wage rates for the Work at conspicuous locations at the Site of the Work. The Contractor and all Subcontractors performing any portion of the Work shall pay not less than the applicable prevailing wage rate for the classification of labor provided by their respective workers in prosecution and execution of the Work. This Project is subject to the provisions of the Labor Compliance Program adopted by the San Francisco Unified School District.

**CONTRACTOR'S LICENSE CLASSIFICATION.** In accordance with the provisions of California Public Contract Code § 3300, the District requires that Bidders possess the following classification(s) of California Contractors License at the time that the Bid Proposals are opened: **Class C-27 (Landscape Contractor) or Class C-36 (Plumbing Contractor) performing the Work.** Any Bidder not so duly and properly licensed shall be subject to all penalties imposed by law.

**JOB WALK.** The District will conduct a **NON-MANDATORY** job walk as set forth herein. Attendance at the job walk is not a requirement to bid for Landscape and Plumbing Contractors. All attendees are required to sign-in to tour the sites. The job walk schedule will be as follows:

Job Walk: **Thursday, November 17, 2011, 10:00 AM.** (Other days and times may be arranged with the Project Manager prior to the due date.)

Bidders shall meet at International Studies Academy (formerly Bryant Elementary School), 1050 York Street, San Francisco, CA 94110 at the date and time for the job walk. Bidders shall meet directly in front of the main entrance along York Street. Upon complete of the job walk, the sites will proceed to Leonard Flynn ES and end at West Portal ES. Further details will be provided during the job walk.

**WAIVER OF IRREGULARITIES.** The District reserves the right to reject any or all Bid Proposals or to waive any irregularities or informalities in any Bid Proposals or in the bidding.

**EQUAL OPPORTUNITY.** The San Francisco Unified School District is an "Equal Opportunity" employer and requires that, if subcontractors are used, reasonable, good-faith outreach efforts be made to all subcontractor enterprises in the local community including African-Americans, Caucasians, Hispanics, Asians, Women and others without discrimination on the basis of race, color, religion, sex or natural origin. We encourage employing residents of the community where the Project is located.

**AWARD OF CONTRACT.** The Contract for the Work, if awarded, will be by action of the District's Board of Education to the responsible Bidder submitting the **lowest priced responsive Total Base Bid Proposal**. The District reserves the right to reject any or all Bid Proposals or to waive any irregularities or informalities in any Bid Proposal or in the bidding.

**ATTACHMENTS:**

- A. Scope of Work and Drawings
- B. Construction Agreement Proposal

**INFORMAL BID REQUEST  
FOR  
PLUMBING SERVICES  
SAN FRANCISCO UNIFIED SCHOOL DISTRICT  
PROP A 2003 BOND GREEN SCHOOLYARD PROGRAM**

---

**PROJECT SCOPE OF WORK AND LOCATIONS**

1) International Studies Academy (formerly Bryant Elementary School), 1050 York Street, San Francisco, CA 94110

- The backflow prevention device at this site failed inspection as it is a Pressure Vacuum Breaker (PVB). In order to pass inspection, a Reduced Pressure (RP) backflow device needs to be installed to replace the PVB device in accordance with the current requirements outlined by the City and County of San Francisco, Department of Public Health Environmental Health's Cross Connection Control Program\* and in accordance to the San Francisco Unified School District Project Standard Guidelines. The backflow preventer enclosure may need to be replaced to accommodate the new RP backflow assembly. See attachment for locations.

2) Leonard R. Flynn Elementary School, 3125 Cesar Chavez Street, San Francisco, CA 94110

- Replace the current three (3) anti-siphon valves with three (3) reduce pressure (RP) backflow device for the same reason noted above. See attachment for locations.

3) West Portal Elementary School, 5 Lenox Way, San Francisco, CA 94127

- On the west side of the campus, replace the current double check backflow preventer located in ground in a green Christi box with a reduce pressure (RP) backflow device for the same reason noted above.
- On the east side of the campus, replace the current anti-siphon valve located in a green Christi box with a reduce pressure (RP) backflow device for the same reason noted above.
- The new backflow devices will need to be secured therefore the enclosures will need to be corrected.
- See attachment for locations.

**GENERAL NOTES:**

Note \*: Backflow Prevention assemblies must pass inspection per the City and County of San Francisco Department of Public Health Environmental Health's Cross Connection Control Program. Requirements can be viewed at: <http://www.sfdph.org/dph/EH/CrossFlow/CrossConnCodes.asp>.



SAN FRANCISCO UNIFIED SCHOOL DISTRICT  
FACILITIES DESIGN & CONSTRUCTION

2006  
PROPOSITION A  
BOND PROGRAM  
135 Van Ness Avenue  
San Francisco, California 94102  
TEL (415) 241-6152  
FAX (415) 241-6148

Landscape Architect

**MILLER COMPANY**  
LANDSCAPE ARCHITECTS

1585 FOLSOM STREET  
SAN FRANCISCO, CA 94103  
415-252-7288  
FAX: 415-252-7289  
www.millercomp.com  
Lic# 2031

Stamp

School Name and Address:  
**Leonard Flynn ES**  
3125 Cesar Chavez St.  
San Francisco, CA

Project Name  
**LEONARD  
FLYNN  
GREEN  
SCHOOLYARD**

Approvals

Date No. Revisions

Date	No.	Revisions

DRAWING TITLE

**PLAN**

SHEET NO. JOB NO.

IRR 1-0 0709

1 OF 2 SHEETS

DATE: 6-21-11 DRAWN BY: PIERRE SITE NO: 680

SCALE: NTS S.F.U.S.D. PROJECT NO. 10786-D

**PRECITA AVENUE**

**CAESAR CHAVEZ STREET**

**MAIN BUILDING  
LEONARD FLYNN**

(2) (E) ANTI-SYPHON VALVES IN ENCLOSURE.  
REPLACE WITH (N) BACKFLOW, AND (2) (N) IRRIGATION VALVES.  
SEE DETAILS.

(2) (E) ANTI-SYPHON VALVES IN ENCLOSURE.  
REPLACE WITH (N) BACKFLOW, AND (2) (N) IRRIGATION VALVES.  
SEE DETAILS.

(2) (E) ANTI-SYPHON VALVES IN ENCLOSURE.  
REPLACE WITH (N) BACKFLOW, AND (2) (N) IRRIGATION VALVES.  
SEE DETAILS.

**HARRISON STREET**

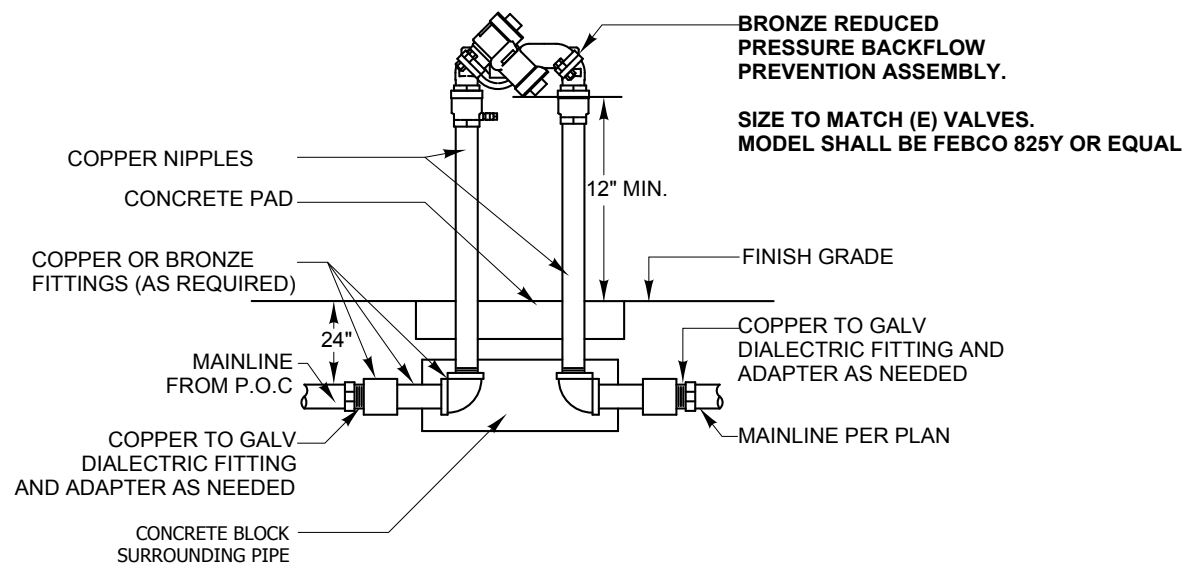

- NOTES:
1. EVENLY COAT METAL FITTINGS EXPOSED TO SOIL AND CONCRETE WITH 3M SCOTCHRAP PIPE PRIMER AND THEN WRAP WITH 3M SCOTCHRAP NO. 51 BLACK TAPE (3/4" OVERLAP).
  2. INSTALL INSIDE EXISTING ENCLOSURE HOUSING REPLACED ANTI-SYPHON VALVES.

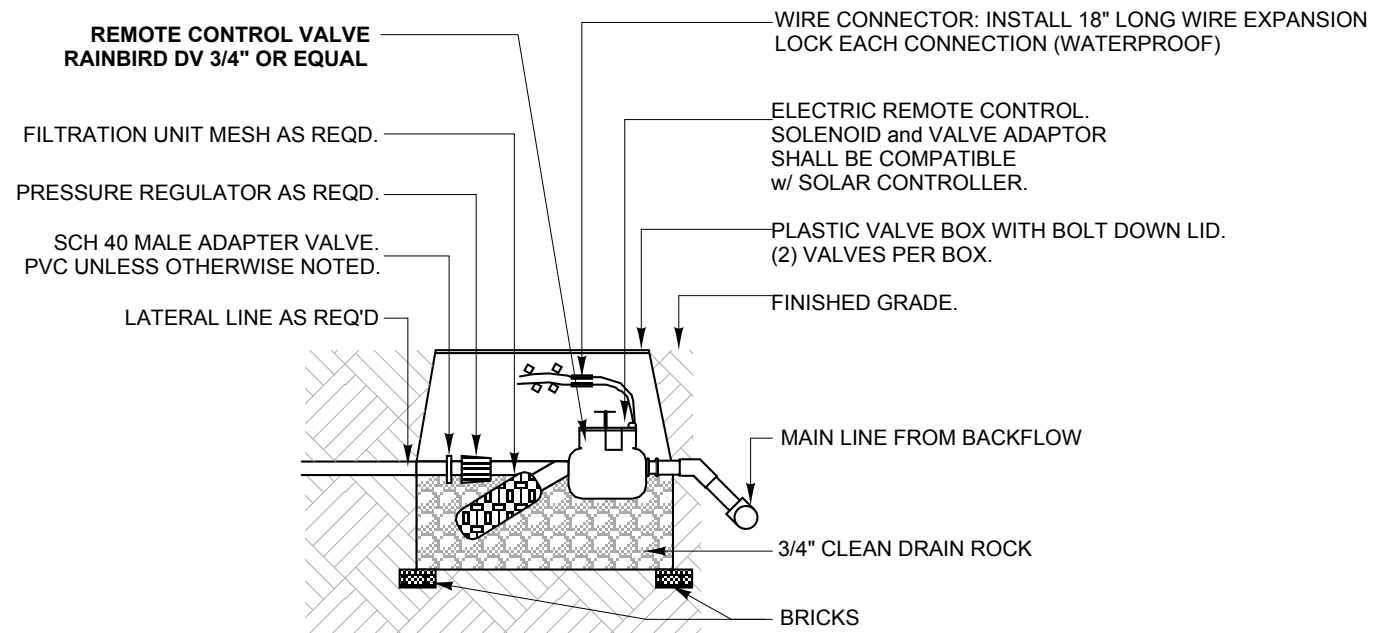

- NOTES:
1. PRESSURE REGULATORS AND FILTRATION UNITS SHALL BE SALVAGED FROM (E) ANTI SYPHON VALVES OR MATCHED.
  2. REATTACH IRRIGATION WIRE TO (N) VALVES. ENSURE THAT SAME IRRIGATION WIRES ARE ATTACHED TO THEIR RESPECTIVE VALVES.
  3. (N) IRRIGATION VALVES SHALL BE ATTACHED TO SAME SOFT IRRIGATION LINES AS THE ANTI\_SYPHON VALVE THAT THEY REPLACE.

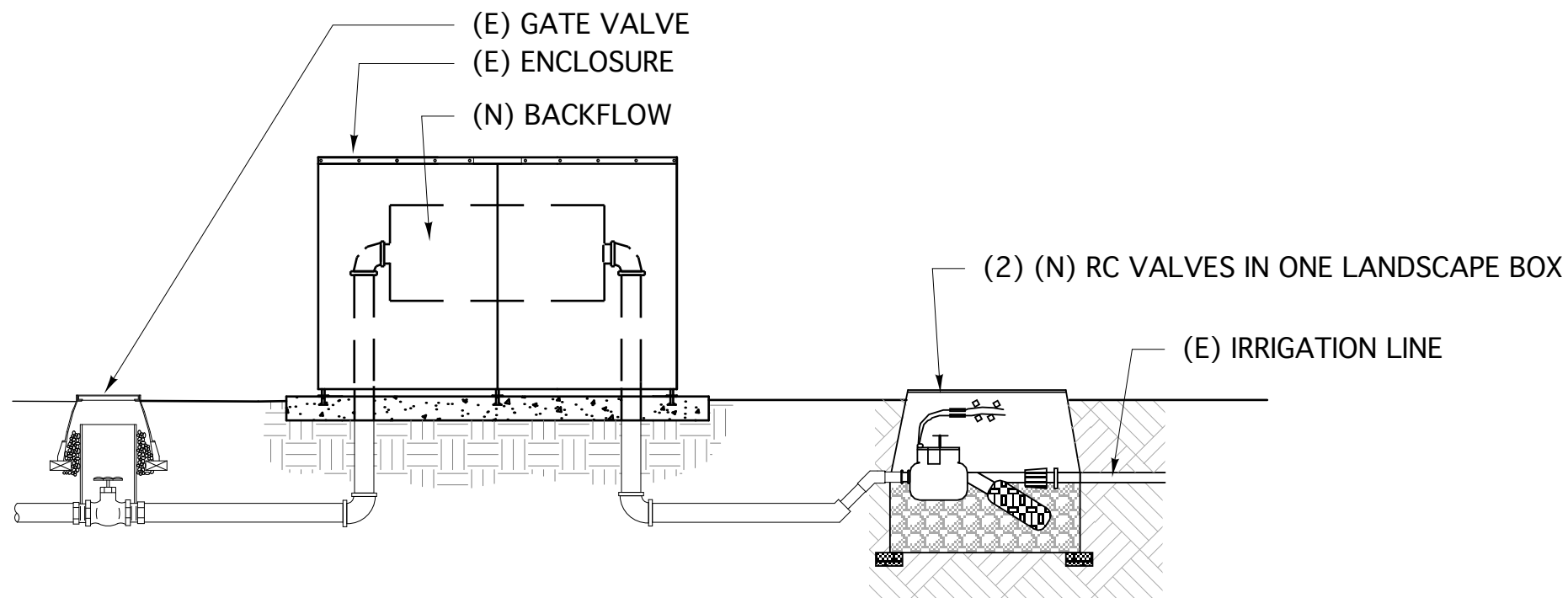

SAN FRANCISCO UNIFIED SCHOOL DISTRICT  
FACILITIES DESIGN & CONSTRUCTION

2006 PROPOSITION A BOND PROGRAM  
135 Van Ness Avenue  
San Francisco, California 94102  
TEL (415) 241-6152  
FAX (415) 241-6148

Landscape Architect

**MILLER COMPANY**  
LANDSCAPE ARCHITECTS

1585 FOLSOM STREET  
SAN FRANCISCO, CA 94103  
415-252-7288  
FAX: 415-252-7289  
www.millercomp.com  
Lic# 2031

Stamp

School Name and Address:  
**Leonard Flynn ES**  
3125 Cesar Chavez St.  
San Francisco, CA

Project Name  
**LEONARD FLYNN GREEN SCHOOLYARD**

Approvals

Date	No.	Revisions

DRAWING TITLE  
**DETAIL**

SHEET NO. 0709  
**IRR 2-0**

2 OF 2 SHEETS

DATE: 6-21-11  
SCALE: NTS

PROJECT NO. 10786-D

**CONSTRUCTION AGREEMENT PROPOSAL**

DISTRICT SITE: \_\_\_\_\_

PROPOSALS WILL BE OPENED AT \_\_\_\_\_ at \_\_\_\_\_ PM  
(If bidders are present at this time.)

At: Facilities Development and Management  
135 Van Ness Avenue, Room 209  
San Francisco, CA 94102

DELIVER THIS PROPOSAL, properly executed, to Facilities Development and Management, prior to opening time, in **SEALED ENVELOPE** with **SCHOOL OR SITE, DATE AND TIME OF PROPOSAL OPENING INSCRIBED ON THE OUTSIDE OF THE ENVELOPE.**

Upon receipt of a "Notice to Proceed" to the selected contractor, the undersigned, hereby promises and agrees to furnish all labor and material applicable to this proposal within the time specified, in the manner and form and at the prices stated on the attached proposal, which is incorporated and made a part of this Agreement, in strict accordance with the specifications, proposal and general conditions, all of which are made a part of the Construction Agreement Proposal.

Acknowledge Receipt of Addenda Nos. \_\_\_\_\_

\_\_\_\_\_  
COMPANY NAME

\_\_\_\_\_  
DATE

\_\_\_\_\_  
SIGNATURE OF BIDDER

\_\_\_\_\_  
TITLE OF BIDDER

\_\_\_\_\_  
BUSINESS ADDRESS

\_\_\_\_\_  
TELEPHONE NUMBER

\_\_\_\_\_  
CITY, STATE, ZIP

\_\_\_\_\_  
FAX NUMBER

If a corporation, incorporated in the State of \_\_\_\_\_.

**GENERAL CONDITIONS, INSTRUCTIONS AND INFORMATION FOR BIDDERS**

1. The contractor must list any subcontractors doing work amounting to over one half of 1% of total bid, including each subcontractor's type of work. Contractor should also include subcontractor's bid price. The San Francisco Unified School District Board of Education encourages participation by minority contractors as both prime contractors and subcontractor. Contractor is requested to fill in the ethnicity and gender of the ownership of his/her firm and to fill in the ethnicity and gender of all subcontractors or sub-consultants on the prime/subcontractors form.
2. The contract documents may include an addendum or addenda and it will be the responsibility of each bidder to call Facilities Development and Management prior to the bid opening date to confirm whether addenda have been issued.
3. The contractor shall be paid as per attached bid which is incorporated herein and made a part of this Agreement. Requests for compensation shall be monthly or upon completion of the work, complete with a breakdown of charges and receipts as applicable. Payments shall be made in a reasonable time upon approval that services and requirements have been rendered in a satisfactory manner.

4. In preparing the Construction Agreement Proposal, the contractor must sign as an original and acknowledge all addenda.

5. Upon approval of selected proposal, the selected contractor must furnish the following certificate of insurance by an insurance company who has obtained a Certificate of Authority (Admitted) from the California Department of Insurance or acceptable to the District before being awarded the contract:

a) Certificates of Insurance: (Admitted in CA)

- |    |   |                |
|----|---|----------------|
| 1. | Public Liability Insurance, including Comprehensive General Liability | (\$1,000,000)  |
| 2. | Worker's Compensation   | (\$1,000,000)  |
| 3. | Automobile Liability  | ( \$500,000)   |
| 4. | Professional Liability (if applicable) <i>minimum</i>                 | ( \$250,000)   |
|    | Projects \$250,000 to \$1,000,000                                     | 10% of Project |

b) Endorsement: A separate endorsement on Form CG 20 10 11 85.

San Francisco Unified School District, its Board, Officers and employees should be named as additional insured on General Liability and Automobile Liability by Endorsement, to be provided with Certificate, specifying the San Francisco Unified School District is noticed by the Company and entitled to a 30-day written mailed notice.

6. The contractor shall defend, indemnify and hold harmless the District, its Board, officers, and employees from and against all claims, costs, lawsuits and damages arising out of the negligent acts, errors and omissions of the consultant to all persons, corporations and partnerships including but not limited to employees of contractor and heirs of employees of consultant and employees and heirs of employees of District arising out of and in the course of the performance of this Agreement. This liability shall not lie in the instances where the damages are caused by the sole negligence or intentional tort of the District or its employees.

7. It is expressly understood and agreed that in the event the contractor or the District fails to perform its obligations under this Agreement, this Agreement shall be terminated and all the contractor's/District's rights hereunder ended. Termination shall be upon ten (10) days written notice to the defaulting party, in which no work will be undertaken after the date of receipt of the notice. In the event this Agreement is terminated by the District pursuant to this paragraph, the contractor shall be paid for services performed up to the date of the termination.

It is further understood and agreed that the District may terminate this Agreement for the District's convenience and without cause at any time by giving the contractor thirty (30) days written notice of such termination. In such an instance, the contractor shall be entitled to compensation for services performed up to the effective date of termination.

Upon receipt of written notice that this Agreement is terminated, the contractor will submit an invoice to the District for an amount which represents the value of services actually performed to the date of termination for which the contractor has not previously been compensated. Upon approval and payment of this invoice by the District, the District shall be under no further obligation to the contractor monetarily or otherwise.

8. Failure or refusal of the contractor to perform or do any act herein required shall constitute a default. In the event of any default, in addition to any other remedy available to the District, this contract may be terminated by the District. Such termination shall not waive any other legal remedies available to the District.



9. The contractor shall be deemed at all times to be an independent contractor and shall be wholly responsible for the manner in which he performs the service required of him under the terms of this Agreement. The contractor shall be liable for any act or acts of his own, or his agents or employees, and nothing contained herein shall be construed as creating the relationship of employer and employee between the District and the contractor or their agents and employees.

10. This Agreement may be amended by the parties in writing by mutual consent. Changes, including any increase or decrease in the amount of the contractor's compensation, shall only be effective upon the execution of a duly authorized written amendment to this Agreement.

11. This Agreement shall be deemed to be made in, and shall be construed in accordance with the laws of the State of California.

12. The contractor shall not assign or delegate any portion of this contract without the written consent of the owner, but such consent does not relieve the contractor of its responsibilities under the contract.

13. Contractor understands the following and certifies that it does not know of any facts which constitute a violation:

a) Contractor hereby certifies that no current Board member or employee of the San Francisco Unified School District, and no one who has been a Board member or who has been employed by the San Francisco Unified School District within the past two years, has participated in bidding, selling or promoting this contract. Furthermore, contractor certifies that no such current or former Board member or employee has an ownership interest in this contract, nor shall any such current or former Board member or employee derive any compensation, directly or indirectly, from this contract. Contractor understands that any violation of this provision of the contract shall make the agreement voidable by the District.

b) Government Code of the State of California, Section 87100 et. seq. Public officials; state and local; financial interest: No public official at any level of state or local government shall make, participate in making or in any way attempt to use his official position to influence a governmental decision in which he knows or has reason to know he has a financial interest.

14. In the event that either party shall cease conducting business in the normal course, become insolvent, make a general assignment for the benefit of creditors, suffer or permit the appointment of a receiver for its business or assets or shall avail itself of, or become subject to, any proceeding under the Federal Bankruptcy Act or any other statute of any state relating to insolvency or the protection of rights of creditors, then at option of the other party, this Agreement shall terminate and be of no further force and effect, and any property or rights of such other party, tangible or intangible, shall forthwith be returned to it.

15. If any term or provision of this Construction Agreement Proposal shall be found illegal or unenforceable, then, notwithstanding, this Agreement shall remain in full force and effect and such term or provision shall be deemed stricken.

16. The omission by either party at any time to enforce any default or right reserved to it, or to require performance of any of the terms, covenants or provisions hereof by the other party at the time designated, shall not be a waiver of any such default or right to which the party is entitled, nor shall it in any way affect the right of the party to enforce such provisions thereafter.

17. Any interest of the contractor in studies, reports, memoranda, computation sheets or other documents prepared by the contractor in connection with services to be performed under this Agreement shall become the property of and will be transmitted to the District. However, the contractor may retain and use copies for reference and as documentation of its experience and capabilities.

18. Contractor agrees that is shall not discriminate on the basis of sex, race, religious reed, national origin, age, marital status, sexual orientation, gender identity, AIDS/ARC/HIV status, or disability, in its performance under this Agreement.

19. Contractor agrees to comply with Education Code, Section 45125.1, et. Seq. concerning fingerprinting employees and conducting criminal background checks through the California Department of Justice. The District is extending this requirement to all types of contractors if they are deemed to have more than limited contact with District students. The contractor shall assume all expenses associated with these background checks and shall immediately remove any employee or agent from District property who has been arrested or convicted of any serious or violent felony, as defined by the California Penal Code Sections 667.5 and 1192.7.

20. The District shall be the final arbiter of what constitutes "limited contact." The District may also, in its sole discretion, waive these provisions if it determines that emergency or exceptional circumstances exist which threaten student or staff safety if the work is delayed pending clearance. The contractor's violation of this section shall constitute a default under Section 12 herein.

21. **Bonds required: Bid-10% of bids over \$15,000; Performance & Payment -100% of bids over \$25,000.**

## IDENTIFICATION LISTING for PRIME CONTRACTOR AND SUBCONTRACTOR

### Prime Contractor

In accordance with Instructions to Bidders, Sections 8 and 9, each Bidder shall complete and submit identification information listed below with his/her Bid Proposal:

NAME of PRIME CONTRACTOR	ADDRESS of BUSINESS	LICENSE Number	ETHNICITY of Owner	GENDER of Owner

### Subcontractor or Supplier

Each Bidder must complete this form and submit with Bid Proposal all subcontractors doing work amounting to over one-half (1/2) of one percent (1%) of total bid, to include location of the place of business and the sub-consultant's, contractor's license number, as per Public Contract Code 4104 (a). All other information required on the form should be filled out. If there are no subcontractors or suppliers, state "NONE".

NAME and ADDRESS of SUBCONTRACTOR and SUPPLIER	TRADE or TYPE of WORK	VALUE (\$ Amount)	LICENSE Number	ETHNICITY of Owner	GENDER of Owner
			#		
			<input type="checkbox"/> Supplier? <input type="checkbox"/> Subcontractor?		
			#		
			<input type="checkbox"/> Supplier? <input type="checkbox"/> Subcontractor?		
			#		
			<input type="checkbox"/> Supplier? <input type="checkbox"/> Subcontractor?		
			#		
			<input type="checkbox"/> Supplier? <input type="checkbox"/> Subcontractor?		
			#		
			<input type="checkbox"/> Supplier? <input type="checkbox"/> Subcontractor?		
			#		
			<input type="checkbox"/> Supplier? <input type="checkbox"/> Subcontractor?		
			#		
			<input type="checkbox"/> Supplier? <input type="checkbox"/> Subcontractor?		
			#		
			<input type="checkbox"/> Supplier? <input type="checkbox"/> Subcontractor?		
			#		
			<input type="checkbox"/> Supplier? <input type="checkbox"/> Subcontractor?		

Ethnicity Codes: AFAM = African American; ARAM = Arab American; ASIAN = Asian or Pacific Islander;  
FEM = Female; HISP = Hispanic; NON = Non Minority

Gender Codes: M = Male; F = Female

# BID SHEET FOR CONSTRUCTION AGREEMENT PROPOSAL

District Site: \_\_\_\_\_

*(Note: This is an informal bid. If your quote is over \$15,000, do not submit your bid using this form as it will not be accepted.)*

[Insert Quote Here]

ACCEPTED BY: \_\_\_\_\_  
David L. Goldin, Chief Facilities Officer

\_\_\_\_\_  
Company

\_\_\_\_\_  
Signature of Bidder

\_\_\_\_\_  
Title of Bidder

**San Francisco Unified School District  
 Consultant/Independent Contractor Agreement  
 Criminal Background Check**

Name of Independent Consultant/Contractor:		
Services performing under the Agreement:		
Schools/Locations where services are being performed:		
Total amount to be paid by the District under this Agreement:	\$	
Term of Agreement:		
<i><b>Check the applicable box and fill in any blanks.</b></i>		
1.		I certify that none of my employees will have more than limited contact (as defined by the District) with District students during the term of the Agreement
2A.		The following employees will have more than limited contact (as defined by the District) with District students during the term of the Agreement (attach and sign additional pages, as needed):
2B.		I certify that the employees noted in 2A above have been fingerprinted under procedures established by the California Department of Justice, and the results of those fingerprints reveal that none of these employees have been arrested or convicted of a serious or violent felony, as defined by the California Penal Code.

Certification by Contractor/Consultant

"I certify that the information provided herein is true and accurate. I further acknowledge that during the term of my Agreement with the District, if I learn of additional information which differs from the responses provided above, I promise to forward this additional information to the District immediately. "

\_\_\_\_\_  
 Consultant's Signature      Date

\_\_\_\_\_  
 Administrator's Signature      Date

\_\_\_\_\_  
 Printed name of Consultant

\_\_\_\_\_  
 Printed name of Administrator